



Replacement Part | Specification

Model (SKU)

PT100-516

PermaTile™ Series Rough-In
5-1/2" On Center Tile Wall Anchor

Applicable Features & Installation Types

- Stainless steel construction with stabilizing bracket and protective thumb screws
- Mortar-based installation system (No mastic or organic adhesives allowed)
- Wall anchor configured specifically for TileWare accessories
- Refer to installation instructions before use
- Tested by TCNA
- BUY US ONCE FOR LIFE

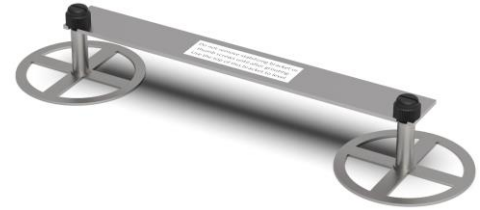

For Tile

T

Tile Thickness Range
5/32" – 1/2" (4mm – 13mm)

- Promessa™ Series
 - Toilet Paper Holders
 - ☐ T105-011
 - ☐ T105-012

Mates with Trim Only

TX

Tile Thickness Range
5/32" – 1/2" (4mm – 13mm)

- Promessa™ Series
 - Toilet Paper Holders
 - ☐ TX105-011
 - ☐ TX105-012



p: 828-322-9273 | f: 828-304-1076
tilewareproducts.com | info@tilewareproducts.com

page 1 of 2
TW-F02-212-PT100 | REV: 8-12-20



Replacement Part | Specification

Model (SKU)

PT100-516

PermaTile™ Series Rough-In
5-1/2" On Center Tile Wall Anchor

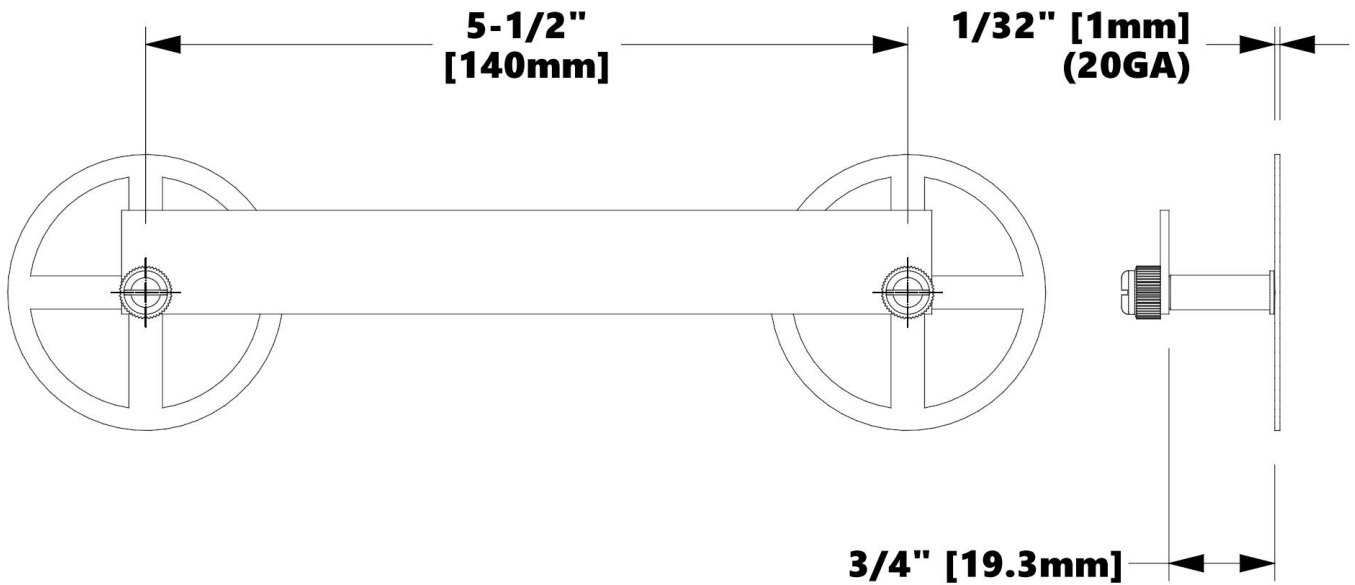

Product Dimensions (units are in both inches and mm)

Weight

0.131 lb / 0.060 kg

828



p: 828-322-9273 | f: 828-304-1076
tilewareproducts.com | info@tilewareproducts.com

page 2 of 2
TW-F02-212-PT100 | REV: 8-12-20