



Replacement Part | Specification

Model (SKU)

PT100-509

PermaTile™ Series Rough-In
18" On Center 'Z' Tile Wall Anchor
For 24" Grab Bars

Applicable Features & Installation Types

- Stainless steel construction with stabilizing bracket and protective thumb screws
- Includes (2) Self Drilling Screws (C200-051)
- Mortar-based installation system (No mastic or organic adhesives allowed)
- Wall anchor configured specifically for TileWare accessories
- Refer to installation instructions before use
- Anchor exceeds ADA 250 lb threshold
- BUY US ONCE FOR LIFE

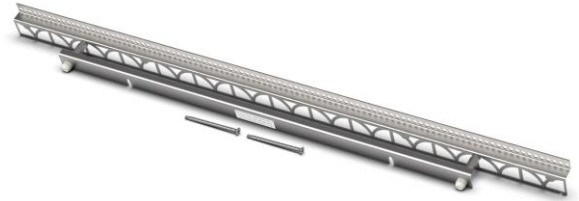

For Tile

T

Tile Thickness Range
5/32" – 1/2" (4mm – 13mm)

- Victoria™ Series
 - Grab Bars
 - T200-011
 - T200-012
 - T200-021
 - T200-022
 - T201-011
 - T201-012
 - T201-021
 - T201-022

Mates with Trim Only

TX

Tile Thickness Range
5/32" – 1/2" (4mm – 13mm)

- Victoria™ Series
 - Grab Bars
 - TX200-011
 - TX200-012
 - TX200-021
 - TX200-022
 - TX201-011
 - TX201-012
 - TX201-021
 - TX201-022



p: 828-322-9273 | f: 828-304-1076
tilewareproducts.com | info@tilewareproducts.com

page 1 of 2
TW-F02-209-PT100 | REV: 8-12-20



Replacement Part | Specification

Model (SKU)

PT100-509

PermaTile™ Series Rough-In
 18" On Center 'Z' Tile Wall Anchor
 For 24" Grab Bars

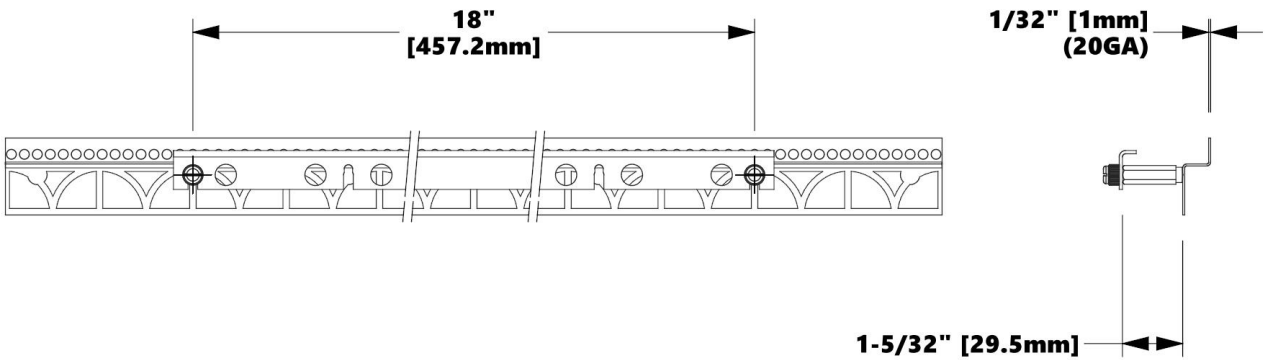

Product Dimensions (units are in both inches and mm)

Weight

0.726 lb / 0.329 kg

817



p: 828-322-9273 | f: 828-304-1076
 tilewareproducts.com | info@tilewareproducts.com

page 2 of 2
 TW-F02-209-PT100 | REV: 8-12-20