



Replacement Part | Specification

Model (SKU)

C200-015

#10-24 x 3/4" Phillips Drive
Flat Head Machine Screw

Applicable Features & Installation Types

- Stainless steel construction with threadlocker
- BUY US ONCE FOR LIFE



Color (Finish)

- Plain

For Tile

T

Tile Thickness Range
5/32" – 1/2" (4mm – 13mm)

- Victoria™ Series
 - Grab Bars
 - T200-001, T200-002**
 - T200-011, T200-012**
 - T200-021, T200-022**
 - T200-031, T200-032**
 - T200-041, T200-042**
 - T201-011, T201-012**
 - T201-021, T201-022**

For Trim Only

TX

Tile Thickness Range
5/32" – 1/2" (4mm – 13mm)

- Victoria™ Series
 - Grab Bars
 - TX200-001, TX200-002**
 - TX200-011, TX200-012**
 - TX200-021, TX200-022**
 - TX200-031, TX200-032**
 - TX200-041, TX200-042**
 - TX201-011, TX201-012**
 - TX201-021, TX201-022**

For Drywall

G

Gypsum Wallboard Surfaces

- Victoria™ Series
 - Grab Bars
 - G200-001, G200-002**
 - G200-011, G200-012**
 - G200-021, G200-022**
 - G200-031, G200-032**
 - G200-041, G200-042**
 - G201-011, G201-012**
 - G201-021, G201-022**



Replacement Part | Specification

Model (SKU)

C200-015

#10-24 x 3/4" Phillips Drive
Flat Head Machine Screw

T	TX	Tile Thickness Grab Bar Screw Configuration Guidelines						
5/32" – 1/2" (4mm – 13mm)		5/32"	3/16"	1/4"	5/16"	3/8"	7/16"	1/2"
Mortar Thickness	1/16"							See C200-027
	3/16"				See C200-027	See C200-027	See C200-027	See C200-027
	3/8"	See C200-027	See C200-027	See C200-027	See C200-027	See C200-027	See C200-027	N/A

T	TX	Tile Thickness with Cover Washer Grab Bar Screw Configuration Guidelines						
5/32" – 1/2" (4mm – 13mm)		5/32"	3/16"	1/4"	5/16"	3/8"	7/16"	1/2"
Mortar Thickness	1/16"					See C200-027	See C200-027	See C200-027
	3/16"			See C200-027	See C200-027	See C200-027	See C200-027	See C200-027
	3/8"	See C200-027	See C200-027	See C200-027	See C200-027	N/A	N/A	N/A

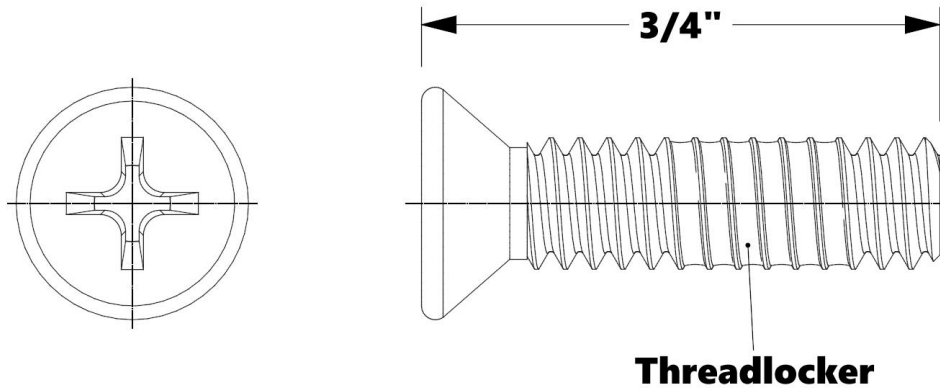

Product Dimensions (units are in inches)

Weight

0.006 lb / 0.003 kg

167