

# PART SPECIFICATION SHEET

**PART: PT100-514**

PERMATILE™ 'ROUGH-IN' FASTENER FOR MATERIAL THICKNESSES FROM - 5/32" TO 7/8" ONLY  
 FASTENERS CONFIGURED SPECIFICALLY FOR TILEWARE ACCESSORIES  
 MORTAR-BASED INSTALLATION SYSTEM - NO MASTIC OR ORGANIC ADHESIVE ALLOWED!  
 REFER TO INSTALLATION INSTRUCTIONS BEFORE USE

PERMATILE™

'ROUGH-IN' ADA 18" GRAB BAR 'Z' FASTENER

COMPATIBLE WITH LISTED MODELS

STAINLESS STEEL

T200-001

T200-002

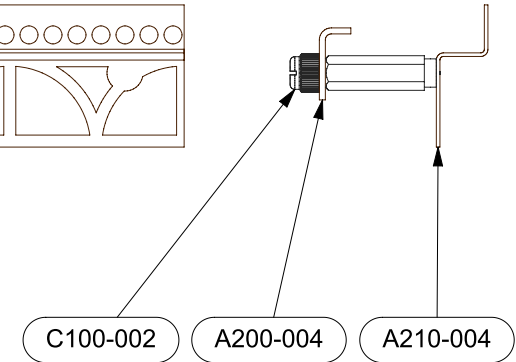
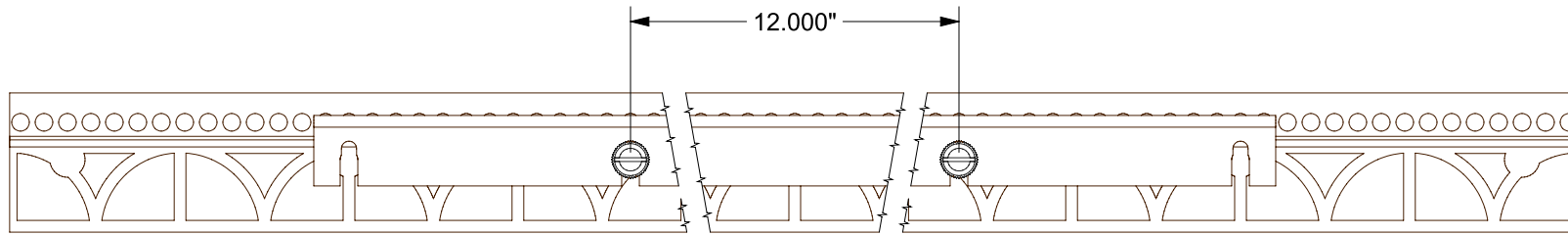
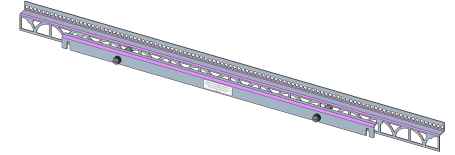

WORKS WITH ALL MATERIAL THICKNESSES

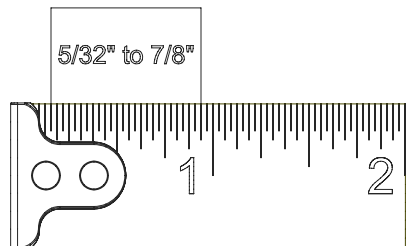

ERP PART #	REFERENCED ABOVE	APPROVALS	DATE
DWG #	357	RLS	7/31/14
SHEET 1 OF 1	SCALE 1:2		
WEIGHT:	0.717 LB	CUBED:	2.570 IN <sup>3</sup>

TW-ENG9



**TileWare Products**  
 www.tilewareproducts.com  
 Office (828) 322-9273 Fax (828) 304-1076